

Fender Super Champ XD >> DSP (Digital) Board Bypass Instructions

PLEASE READ EVERYTHING ENTIRELY BEFORE YOU START!

This instruction is designed to modify a Fender Super Champ XD amplifier such that the DSP board will be eliminated from the circuit. Typically, it would apply in those cases where trouble with the digital portion of the amp is experienced yet the remainder (analog/tube portion) is working. But, before blaming the digital board, it is good practice to verify that the tubes are good or there is not some other problem such as a disconnected speaker wire or blown fuse.

Although I modified a Super Champ XD, other amps (such as the Vibro Champ XD) may be good candidates for this modification as well.

Understand that what is being accomplished here is to (1) bypass the DSP (digital) board and (2) create a tone control (unfortunately, the factory tone adjustment was handled in the DSP board). To accomplish this, R84 ("GAIN") and R85 ("VOLUME 1") are re-purposed. See **Appendix 1 - Schematic**.

When completed, the procedure described below will allow you to adjust **VOLUME** and **BRIGHTNESS (TONE)** – **nothing else!** It assumes that you want to retain the "tube amp" sound and that any added effects will be inserted between the instrument output and the amp input. See **Appendix 2 – Frequency Response Data** to see the effect of the Brightness Control.

I accept no responsibility in the outcome of your project (since you are the one doing it), but I am confident that if you follow these directions studiously, you will end up with a reliable great Fender tube amp!

If you should have questions, comments, or you have adapted this procedure to another amp, please email me at: dbtech@brasherweb.com

This procedure expects the technician to have good workmanship/soldering skills and the necessary tools to work on printed-circuit assemblies and leaded parts, including low/medium power soldering iron and heat gun. Additionally, a Dremel type cutting tool or X-Acto type knife is required. An ohm-meter/multimeter is desirable.

Please be safe and wear protective eyewear!

PARTS LIST:

- 1 ea. 10,000 ohm, 1/8, 1/4, or 1/2-watt resistor
 - 1 ea. .03 micro-farad (μF) capacitor, 100 VDC or more – can be fabricated and material is not important. Below are examples of two combinations that may be used:
 - A) Use a .01 μF and a .02 μF (100V or more each), see Figure 10a
 - B) Use three .01 μF (100V or more each), see Figure 10b
 - C) Any other combination that is equivalent to .03 μF total at 100V or more
 - 1 ea. 4.7 or 5.0 μF capacitor, 100 VDC or more
 - 1 ft. 24 or 26 gauge hookup wire (color not important; I used blue)
 - 1 ft. Heat shrink tubing (HST), size 3/32" or 1/8"
 - 3 tie wraps or some lacing twine
 - Label maker (if you want to re-label front-panel controls)
-

STEP-BY-STEP INSTRUCTIONS:

NOTE – where the cutting of PCB traces is indicated, use a Dremel type tool or an appropriate X-Acto type knife and blade.

⚠ Unplug AC Power and Speaker plugs from chassis.

Remove the four screws securing chassis to cabinet and remove chassis. Do not remove any printed circuit boards from the chassis! Be careful of the tubes – you may wish to remove them.

Orient bottom of chassis as shown in Figure 1a.

Unplug the ribbon cable from P5 and the DSP board and set aside (it is no longer needed).

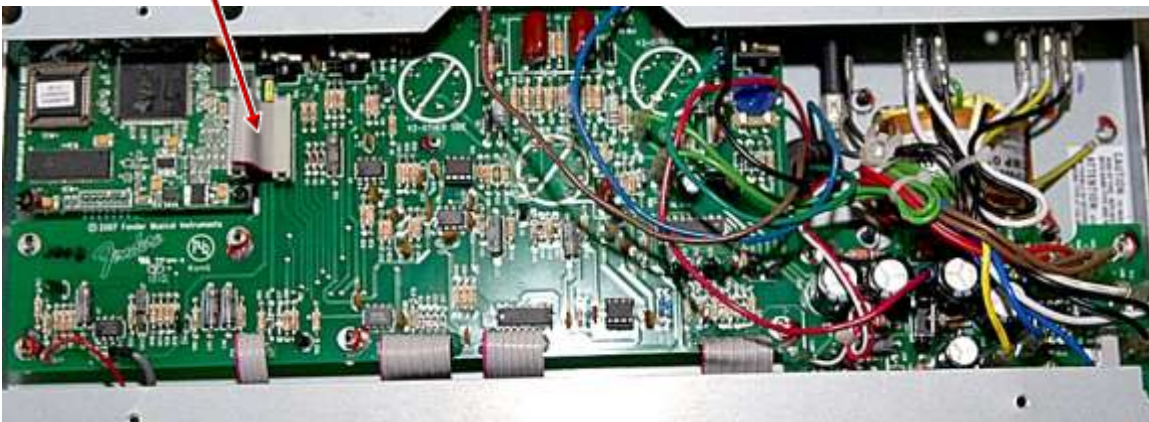

Figure 1a – Orientation of Chassis

The “Breakaway” board with all controls is hidden by chassis lip above but shown in here in Figure 1b.

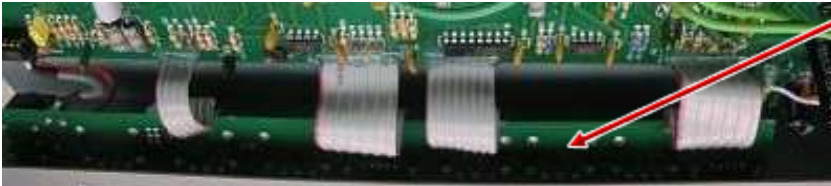

Figure 1b – Orientation of Breakaway Board

On the Breakaway board, there are 3 thru-hole points (A, B, C, in photo below) of contact for **R84 (GAIN)** and **R85 (VOLUME 1)**. The blue wires and jumpers come later so ignore them for now.

After making the following cuts in the traces, the trace should be checked with an ohm-meter to verify it is indeed “open”; if the meter indicates zero ohms, the trace hasn’t been completely cut.

FOR R85 ONLY (the left-most control next to INPUT jack when oriented as in Figure 1): cut PCB trace where circled, between R85 terminal A and the via (thru-hole in PCB) as shown in Figure 2.

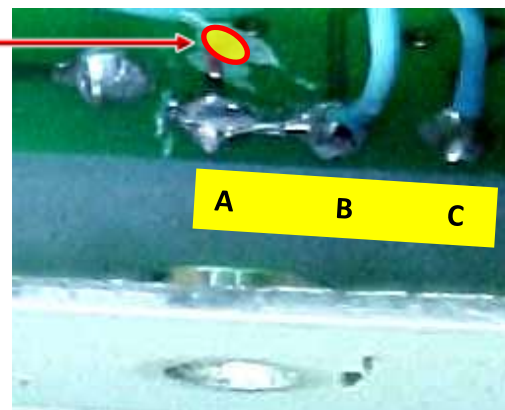

Figure 2 – R85

FOR R84 ONLY: 1

A. Cut PCB trace where circled, between R84 terminal A and the via (thru-hole in PCB) as shown in Figure 3.

B. Cut PCB traces (2 places – where circled) above and next to terminal C, thus isolating this terminal.

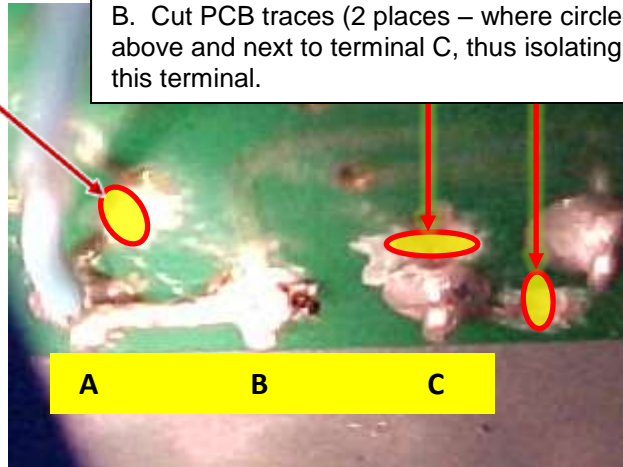

Figure 3 – R84

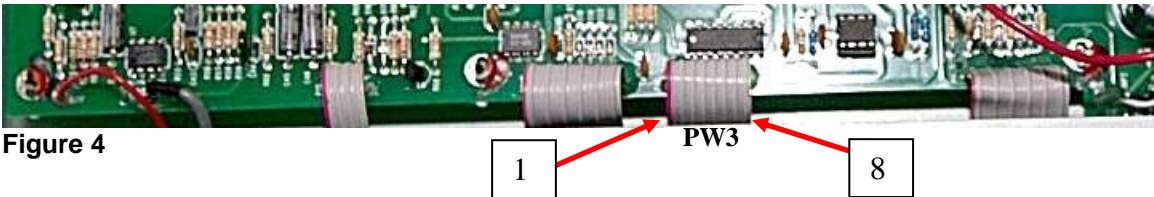

Figure 4

On ribbon cable PW3, the red-striped side is conductor #1 for our purposes.

Near the middle of the ribbon cable (see Figure 5), cut conductors #1, #2, #3, and #8 (#8 being the farthest from the red striped side).

Separate the cut conductors from the rest of the ribbon and install heat-shrink-tubing (HST) on each lead as shown in Figure 5.

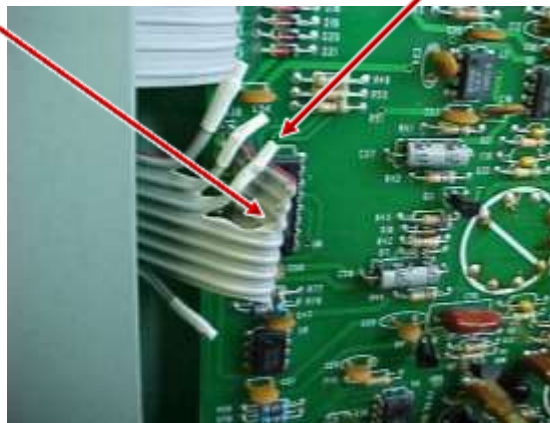

Figure 5

Connect a bare wire from P5 pin 11 (L-out-/R-out) to P5 pin 5 (AGND) as shown in Figure 6a.

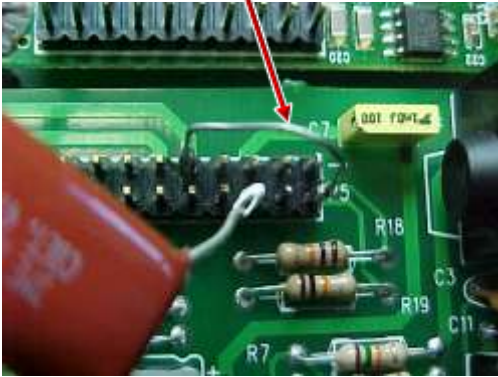

Figure 6a



Figure 6b

Trim one end of the 4.7 (or 5) μ F cap to $\frac{1}{2}$ -inch. Tin P5 pin 13 and the trimmed lead on the cap. Slide a $\frac{1}{4}$ " piece of HST over the lead. Solder the lead to P5 pin 13. Slide the HST down over the P5 pin and shrink it there. Finished step is shown in Figure 6b.

Cut the free end of the cap and one end of the 10K resistor to $\frac{1}{4}$ ". Tin each of these leads, lay them against each other lengthways and solder them together. Slide a $\frac{5}{8}$ " piece of HST over the resistor and the connection all the way to the cap body and shrink it there. See Figure 7 circled area for the finished step.



Figure 7



Figure 8

Slide a $\frac{1}{4}$ -inch piece of HST over the bare wire from the 10K resistor. Solder the wire to P5, Pin 1, as shown in Figure 8, keeping the HST clear of the heated area of the wire until cool. Then, slide the HST over the P5 pin and shrink it there. The finished step is shown in Figure 8.

WIRING TO R85

1. Cut a wire about 4" long. Strip 1/16" from each end. Connect one end to terminal C of R85 and the other end to the left (lower) end of R52.

2. Cut a wire to about 4". Strip approximately 1/8" from one end of the wire and solder it to the right (upper) end of R63.

3. Strip approximately 1/4" from the other end of the wire & bend it at about 90° and tin it. Now solder it to terminals A and B of R85 as shown.

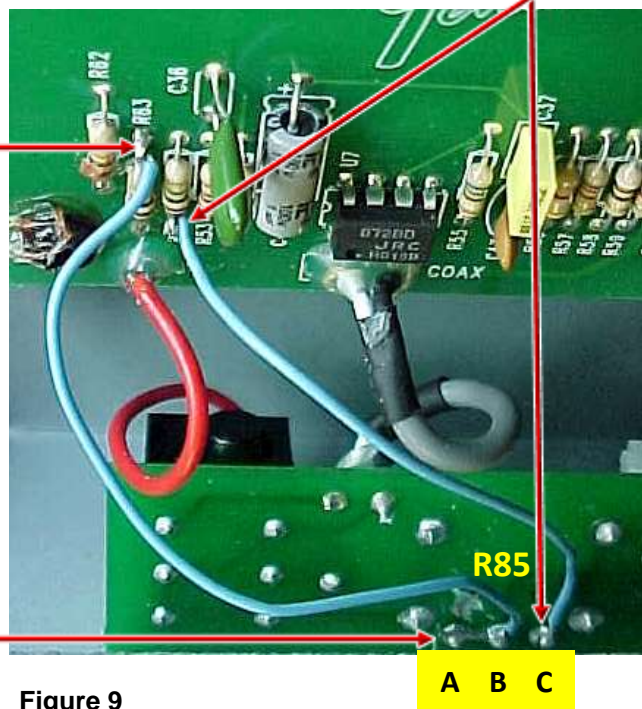

Figure 9

CREATE A .03 μ F CAPACITOR (two different combinations shown)

A) Using a .01 μ F and .02 μ F to create the .03 μ F needed, solder the caps in parallel like this:



Figure 10a – Parallel .01 μ F and .02 μ F Capacitors

B) Using three .01 μ F caps to create the .03 μ F needed, twist the leads together like this and solder them:



Figure 10b – Parallel .01 μ F Capacitors

WIRING TO R84

1. Cut a wire about 4" long. Strip about 1/8" from one end and 1/4" from the other. Bend the 1/4" stripped portion to 90° in relation to the insulated part. Tin both ends and the three terminals of R84.

2. Solder the 1/8" stripped end to the bare wire between the 10K resistor and P5, pin 1, close to the resistor as shown in Figure 11 (refer to Figure 7 also).

3. Solder the 1/4" tinned end to terminals A and B of R84 as shown.

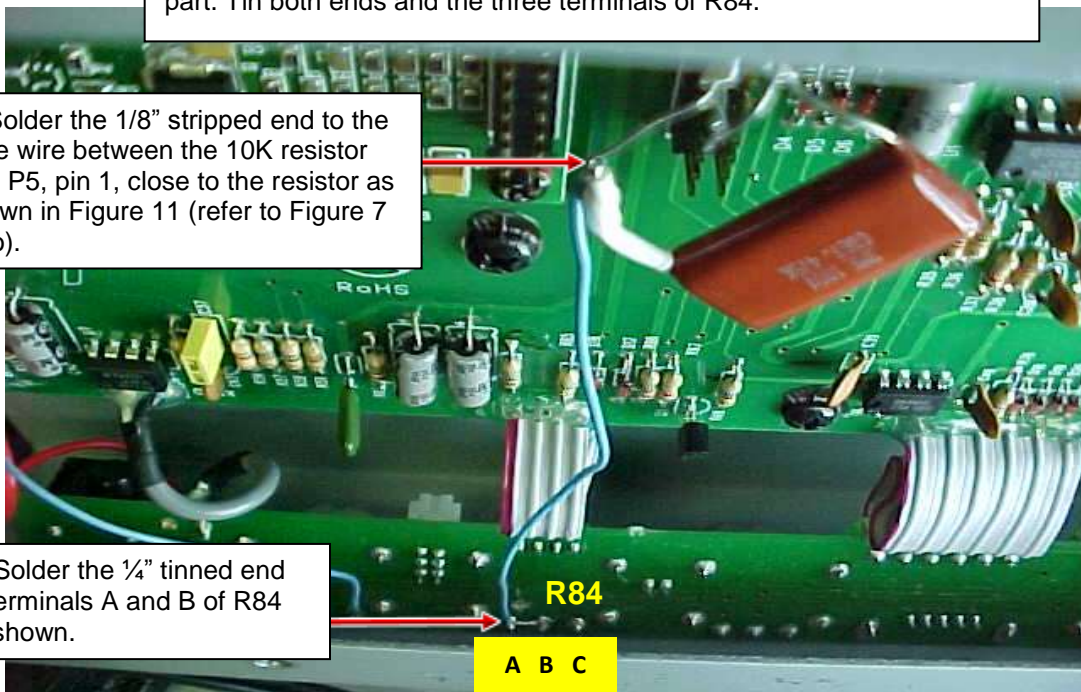

Figure11

4a. Slide piece of HST over the entirety of one lead of the .03uF capacitor pair created in a previous step to cover all but about 1/6th inch at the end.

4b. Solder this end to terminal C of R84.

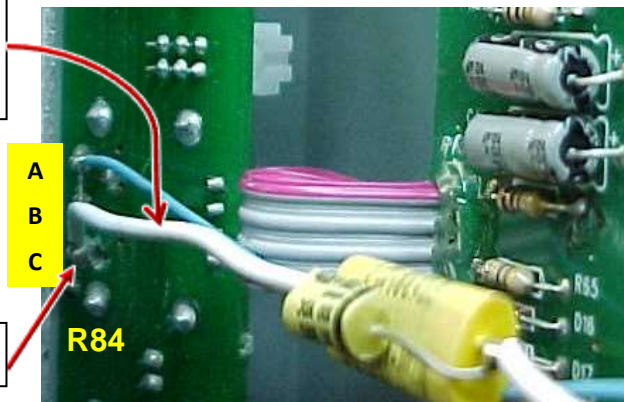

Figure 12

5. Trim the other end of the capacitor pair to reach to the midway point on the bare jumper between J5 pin 5, and J5 pin 11. Slide piece of HST over this lead to cover all but 1/16th inch at the end. Form a hook in the end of this lead and clamp it around the jumper and solder. See circled area in Figure 13. Shrink all HST in place. **NOTE:** If your .03 μF cap doesn't reach, you will need to add enough wire so it may be connected as shown.



Figure 13

To stabilize the flying components and wires, tie them off with lacing twine or cable ties at the points shown in Figure 14.

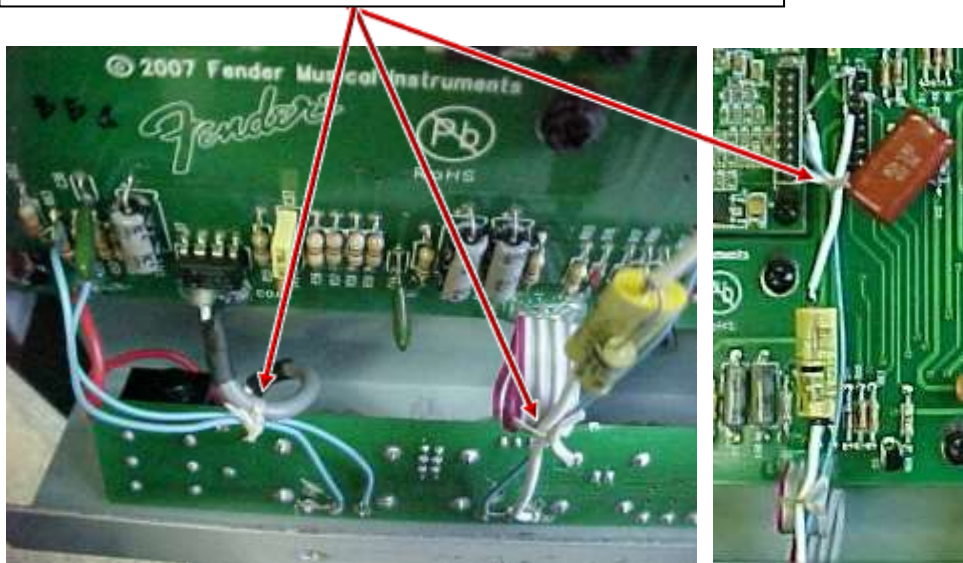

Figure 14 (a and b)

Assemble the chassis into the cabinet in reverse order of disassembly. When re-assembling chassis into cabinet, make sure all components and wires are below the chassis edges so they aren't able to contact the cabinet. Remember, the cabinet is lined with foil in the chassis area!

Here is how I re-labeled the two affected controls on the front panel:



- RED INDICATES CHANGED OR NEW CIRCUITRY
- "X" INDICATES CUT TRACE OR WIRE

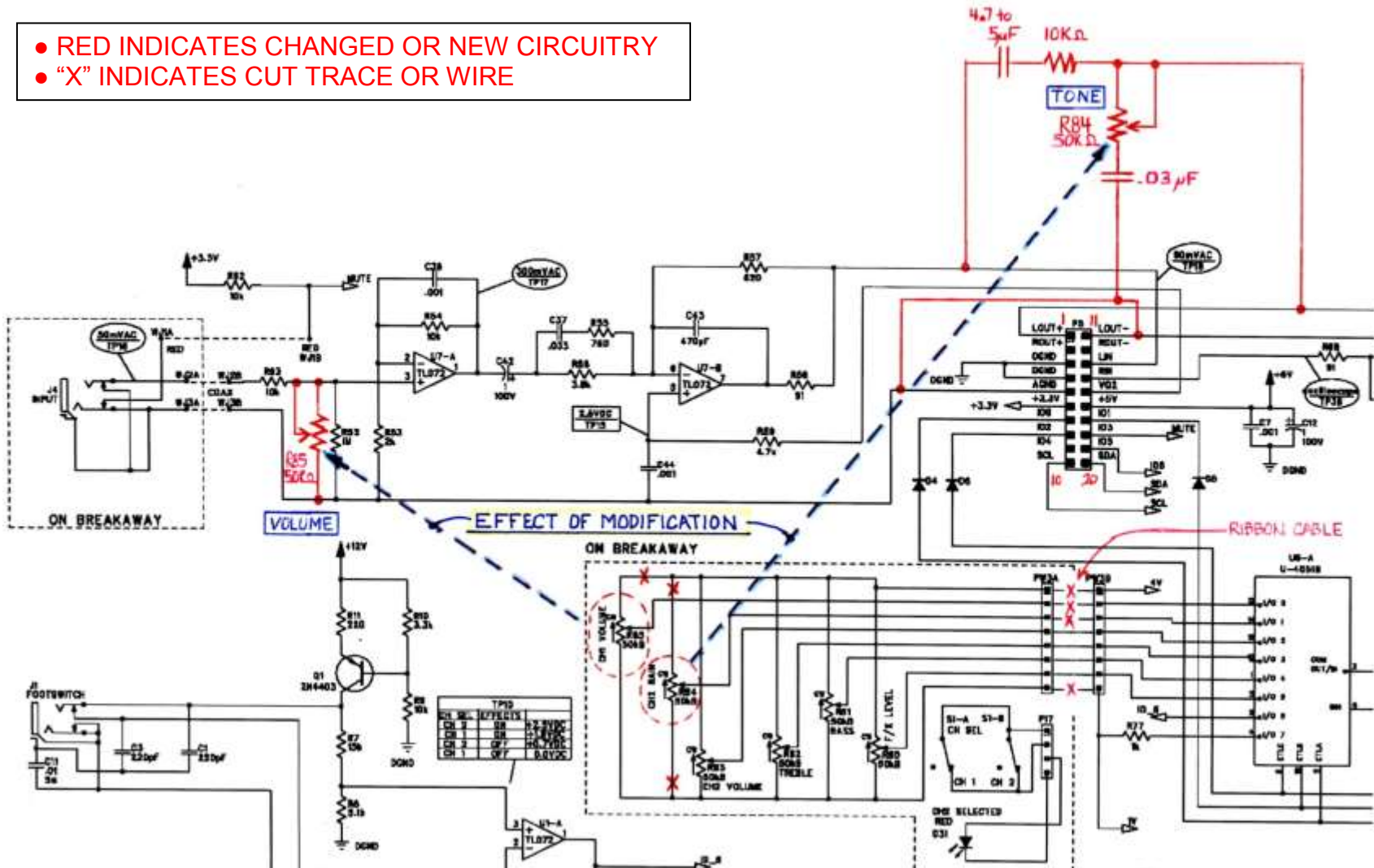

Appendix 1 – Schematic showing changes

FREQUENCY RESPONSE DATA

(Fender Super Champ XD with DSP bypass mod, measured at speaker terminals)

FLAT (Dial=1) dBm (8Ω)	BRIGHT (Dial=10) dBm (8Ω)	FREQUENCY
3.98	3.06	50
7.50	5.92	70
10.00	7.79	100
9.78	7.79	500
9.89	9.89	750
10.00	10.00	1000
10.42	13.52	2000
10.00	14.86	3000
9.08	16.55	4000
8.59	17.51	5000
8.06	18.38	6000
7.50	18.38	7000
6.26	18.38	8000
5.19	17.96	9000
4.40	17.51	10000

With FLAT/BRIGHT dial at "1", the output at the speaker terminals varies less than 3dB from 70 Hz to 7kHz.

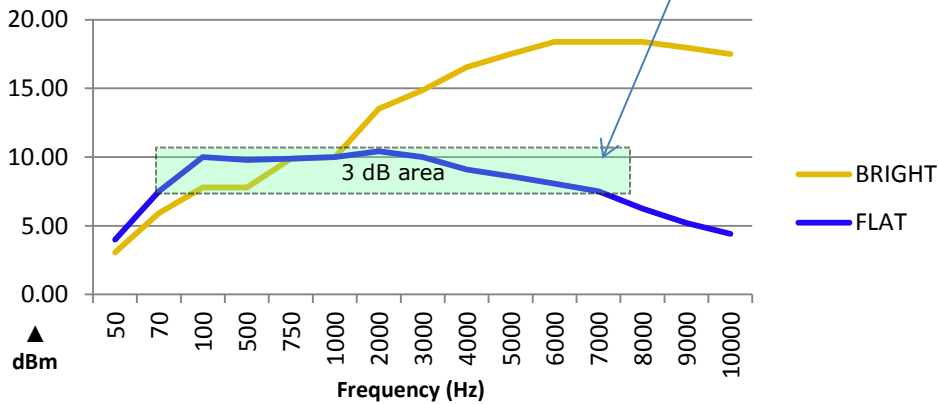

Appendix 2 – Frequency Response Data